

Bill Of Quantities (BOQ)
For the Twin pit latrine construction
German Red Cross, PMO, Cox's Bazar

Contents of Twin pit Latrine Construction (Twin Pit- Single Cubicle)



Lot - 01: 58 Unit Latrine

Item	Description of work/ Specifications	Unit	Quantity	Unit Price	Amount
1	Mobilization: Mobilization and transportation of all kind of materials, equipments to the site for construction of Latrine	Item	1		
2	Earth work in excavation of Foundation for twin pit latrine, carrying and disposing of all Excavated materials at a safe distance. All types of soil except rocky gravelly, organic maintains proper slope, disposing of all back filling of sites of all excavated materials to a safe distance back filling of sites of original level etc, all complete to the direction of the Engineer In Charge.	m ³	4.20		
3	Sand Filling: Sand filling in foundation trenches and plinth with fine local sand having minimum fineness modulus (FM) of .50 in 150mm /75 mm layers, leveling, watering and consolidating each layer by layer up to finished level, etc. All filling completed as per direction of engineer-in-charge and as per drawing and design.	m ³	0.50		
4	Polyethylene Sheet: Providing single layer polythene sheet (0.18mm thick) weighting one kilogram per 6.5 square meter in floor or anywhere in ground floor underneath the cement concrete, etc. all complete as per specifications and direction of the Engineer In-charge.	Sqm	2.00		
5	Brick Flat Soling (3"): Single layer of brick flat apron in foundation with 1st class or picked bricks preparation of bed and filling interstices with local sand, etc. All work completed as per direction of engineer-in-charge and as per drawing and design.	Sqm	3.10		
6	Mass Concrete (1:2:4): Plain cement concrete work in foundation or floor with best quality Portland cement, sand (minimum FM 1.20) and 1st class/picked brick chips 20mm downgraded (LAA value not exceeding 40), including shuttering, (Shuttering works in/c centering, leveling making shuttering fully leak proof, etc. Including all shuttering materials) mixing by concrete mixer machine/manually, casting, laying compacting and curing for 7 days etc. all complete as per direction of the engineer-in charge.	m ³	1.00		
7	Brick work with mortar 1:4: 10" Brick work with 1st class bricks in cement mortar (1:4) and making bond with connected walls & stair in/c necessary scaffolding, racking out joints, cleaning and soaking the bricks at least for 24 hours before use, washing of sand, curing for requisite period etc. all complete as per direction of the Engineer In-charge.	m ³	0.60		

Bill Of Quantities (BOQ)
For the Twin pit latrine construction
German Red Cross, PMO, Cox's Bazar

Contents of Twin pit Latrine Construction (Twin Pit- Single Cubicle)



Lot - 01: 58 Unit Latrine

Item	Description of work/ Specifications	Unit	Quantity	Unit Price	Amount
8	125mm (5") Brick work with mortar 1:4: 5" Brick work with 1st class bricks in cement mortar (1:4) and making bond with connected walls in/c necessary scaffolding, racking out joints, cleaning and soaking the bricks at least for 24 hours before use, washing of sand, curing for requisite period etc. all complete as per direction of the Engineer In charge.	Sqm	2.30		
9	12 mm thick plaster with NCF: Plastering interior and outer wall: minimum 1/2 in. thick cement plaster with (1:4) to outer wall; finishing corner and edges; cleaning the surface, plastering work on the outer surface of precast column ,all plastering completed as per direction of engineer-in-charge and as per drawing and design.	Sqm	21.00		
10	0.46 mm thick (Colored) Corrugated CGI Sheet for Roofing: Supplying, fitting and fixing 1mm thick corrugated CGI sheet (Brand Quality), fitting and fixing on wooden frame with Umbrella nail. All complete and accepted by the Engineer.	Sqm	5.40		
11	0.46 mm/24 gauge thick (Colored) Plain Galvanized Iron Sheet for Wall Fencing & Door: Supplying, fitting and fixing 0.46 mm/24 gauge thick plain galvanized iron sheet (Brand Quality) for fitting and fixing on wooden purlin with screws, limpet washers and putty etc. all complete and accepted by the Engineer.	Sqm	13.00		
12	Wood Work (Gorjon/Akashmoni/Mehogini): Timber used for wood work shall be well seasoned. It shall be free from all defects such as large or loose knots, shakes, saps, upsets, wane edge and twisted fiber. It shall also be free from all disease such as decay, wet rot, dry rot and woodworms and white and timber should be finished to the exact dimension shown on the drawing or as per Engineer direction.	m ³	0.25		

Bill Of Quantities (BOQ)
For the Twin pit latrine construction
German Red Cross, PMO, Cox's Bazar

Contents of Twin pit Latrine Construction (Twin Pit- Single Cubicle)



Lot - 01: 58 Unit Latrine

Item	Description of work/ Specifications	Unit	Quantity	Unit Price	Amount
13	10ft 6 inch height pre-cast pile (4" x 4" size) with reinforced cement concrete works with minimum cement content relates to mix ratio 1:1.5:3 having minimum f'cr = 30 Mpa, and satisfying specified compressive strength f'c = 25 Mpa at 28 days on standard cylinders as per standard practice of Code ACI/BNBC/ASTM best quality coarse sand (F.M.2.2), 20 mm down well graded stone chips conforming to ASTM C-33, mixing in standard mixture machine and centering and shuttering with M.S sheet, M.S angle, F.I bar, nuts and bolts, preparation of bed, laying polythene, placing of reinforcement cage in position, castin& compacting by vibrators and tapered rods, curing for 28 days etc. including cost of reinforcement, water, electricity and other charges as per design and drawing,etc and including plaster of pre cast pile. All complete as per design, drawing and accepted by the Engineer.	nos	4		
14	Supply, fittings & fixing of 36 " dia. RCC Ring, 2.25" thickness and 6 mm ms bar used as reinforcement three layer horizontally and 6 inch spacing vertically binding with GI wire .1.10'x1.10'inspection pit as per the drawing and instruction of EIC.	nos	13		
15	Supplying fitting fixing of ceramic pan, size of pan 550mmx440x190 mm. RAK, Geat wall or equivalent.	nos	1		
16	Supply, fittings & fixing of pre-cast ring cover 38" , thikness-3" made of 1:2:4 mixing ratio, 8mm dia ms rod (60G) 5" C/C both way as per the drawing and instruction of EIC.	nos	3		
17	Hand Rail: Hand rail made with 1.5" SS pipe, supplying ,casting and installation as per the drawing and instruction of EIC.	nos	1		
18	Soak Pit: Supplying and filling the brick chips in Soak pit as per the drawing and instruction of EIC.	cft	15.00		
19	Other Supplies & Accessories fitting, fixing & supplying				
a	Stud Nail (2.5 inch)	kg	2.00		
b	MS Clamp Size 1-6'' x 2.5''x3mm Thickness	nos	4		
c	Nail Different size (1.5 to 4 inch)	kg	1.50		
d	Hinges	nos	3		
e	Screw for Hinges	dozen	1		
f	Lock Chain (Small for door lock inside & outside with handel)	nos	2		

Bill Of Quantities (BOQ)
For the Twin pit latrine construction
German Red Cross, PMO, Cox's Bazar

Contents of Twin pit Latrine Construction (Twin Pit- Single Cubicle)



Lot - 01: 58 Unit Latrine

Item	Description of work/ Specifications	Unit	Quantity	Unit Price	Amount
g	PVC pipe (3" dia) Gas Pipe	m	6.00		
h	uPVC Long Trap (4" dia)	nos	1		
i	uPVC pipe (4" dia)	m	6.00		
j	Wall Hanger	nos	2		
k	Soap Case (MS)	nos	1		
l	Chain with 50 mm china lock for latrine door	nos	2		
m	Latrine Name Plate Supply: Supplying, fitting and fixing of name plate (1'- 0"x 0'-10"x 17±1 mm thickness) with 2- logo and written text (English), 4 color, all complete as per given sample and instruction of Engineer In Charge.	nos	1		
20	Transportation / carrying / mobilization cost: at Six different villages in baharchora and Teknaf Sadar Union, Teknaf.	nos	1		
Total price for per Unit of latrine (BDT)=					
Total price offer for 58 units of latrine (BDT)=					
Vat (7.5%)					
Total price offer for 58 units of latrine (Including VAT)					

The price must need to including TAX since GRC will deduct TDS (Tax Deduction on Source) & VAT as per government

Validity of this quotation is until 31 December 2022.

Delivery time: (6 Villages in Baharchora and Teknaf Sadar Union, Teknaf.) :

Date of Quotation:

Stamp and Signature of Bidder

Bill Of Quantities (BOQ)
For the Twin pit latrine construction
German Red Cross, PMO, Cox's Bazar

Contents of Twin pit Latrine Construction (Twin Pit- Single Cubicle)



Lot 02 & 03: 57 Unit Latrine

Item	Description of work/ Specifications	Unit	Quantity	Unit Price	Amount
1	Mobilization: Mobilization and transportation of all kind of materials, equipments to the site for construction of Latrine	Item	1		
2	Earth work in excavation of Foundation for twin pit latrine, carrying and disposing of all Excavated materials at a safe distance. All types of soil except rocky gravelly, organic maintains proper slope, disposing of all back filling of sites of all excavated materials to a safe distance back filling of sites of original level etc, all complete to the direction of the Engineer In Charge.	m ³	4.20		
3	Sand Filling: Sand filling in foundation trenches and plinth with fine local sand having minimum fineness modulus (FM) of .50 in 150mm /75 mm layers, leveling, watering and consolidating each layer by layer up to finished level, etc. All filling completed as per direction of engineer-in-charge and as per drawing and design.	m ³	0.50		
4	Polyethylene Sheet: Providing single layer polythene sheet (0.18mm thick) weighting one kilogram per 6.5 square meter in floor or anywhere in ground floor underneath the cement concrete, etc. all complete as per specifications and direction of the Engineer In-charge.	Sqm	2.00		
5	Brick Flat Soling (3"): Single layer of brick flat apron in foundation with 1st class or picked bricks preparation of bed and filling interstices with local sand, etc. All work completed as per direction of engineer-in-charge and as per drawing and design.	Sqm	3.10		
6	Mass Concrete (1:2:4): Plain cement concrete work in foundation or floor with best quality Portland cement, sand (minimum FM 1.20) and 1st class/picked brick chips 20mm downgraded (LAA value not exceeding 40), including shuttering, (Shuttering works in/c centering, leveling making shuttering fully leak proof, etc. Including all shuttering materials) mixing by concrete mixer machine/manually, casting, laying compacting and curing for 7 days etc. all complete as per direction of the engineer-in charge.	m ³	1.00		
7	Brick work with mortar 1:4: 10" Brick work with 1st class bricks in cement mortar (1:4) and making bond with connected walls & stair in/c necessary scaffolding, racking out joints, cleaning and soaking the bricks at least for 24 hours before use, washing of sand, curing for requisite period etc. all complete as per direction of the Engineer In-charge.	m ³	0.60		

Bill Of Quantities (BOQ)
For the Twin pit latrine construction
German Red Cross, PMO, Cox's Bazar

Contents of Twin pit Latrine Construction (Twin Pit- Single Cubicle)



Lot 02 & 03: 57 Unit Latrine

Item	Description of work/ Specifications	Unit	Quantity	Unit Price	Amount
8	125mm (5") Brick work with mortar 1:4: 5" Brick work with 1st class bricks in cement mortar (1:4) and making bond with connected walls in/c necessary scaffolding, racking out joints, cleaning and soaking the bricks at least for 24 hours before use, washing of sand, curing for requisite period etc. all complete as per direction of the Engineer In charge.	Sqm	2.30		
9	12 mm thick plaster with NCF: Plastering interior and outer wall: minimum 1/2 in. thick cement plaster with (1:4) to outer wall; finishing corner and edges; cleaning the surface, plastering work on the outer surface of precast column ,all plastering completed as per direction of engineer-in-charge and as per drawing and design.	Sqm	21.00		
10	0.46 mm thick (Colored) Corrugated CGI Sheet for Roofing: Supplying, fitting and fixing 1mm thick corrugated CGI sheet (Brand Quality), fitting and fixing on wooden frame with Umbrella nail. All complete and accepted by the Engineer.	Sqm	5.40		
11	0.46 mm/24 gauge thick (Colored) Plain Galvanized Iron Sheet for Wall Fencing & Door: Supplying, fitting and fixing 0.46 mm/24 gauge thick plain galvanized iron sheet (Brand Quality) for fitting and fixing on wooden purlin with screws, limpet washers and putty etc. all complete and accepted by the Engineer.	Sqm	13.00		
12	Wood Work (Gorjon/Akashmoni/Mehogini): Timber used for wood work shall be well seasoned. It shall be free from all defects such as large or loose knots, shakes, saps, upsets, wane edge and twisted fiber. It shall also be free from all disease such as decay, wet rot, dry rot and woodworms and white and timber should be finished to the exact dimension shown on the drawing or as per Engineer direction.	m ³	0.25		

Bill Of Quantities (BOQ)
For the Twin pit latrine construction
German Red Cross, PMO, Cox's Bazar

Contents of Twin pit Latrine Construction (Twin Pit- Single Cubicle)



Lot 02 & 03: 57 Unit Latrine

Item	Description of work/ Specifications	Unit	Quantity	Unit Price	Amount
13	10ft 6 inch height pre-cast pile (4" x 4" size) with reinforced cement concrete works with minimum cement content relates to mix ratio 1:1.5:3 having minimum f'cr = 30 Mpa, and satisfying specified compressive strength f'c = 25 Mpa at 28 days on standard cylinders as per standard practice of Code ACI/BNBC/ASTM best quality coarse sand (F.M.2.2), 20 mm down well graded stone chips conforming to ASTM C-33, mixing in standard mixture machine and centering and shuttering with M.S sheet, M.S angle, F.I bar, nuts and bolts, preparation of bed, laying polythene, placing of reinforcement cage in position, castin& compacting by vibrators and tapered rods, curing for 28 days etc. including cost of reinforcement, water, electricity and other charges as per design and drawing,etc and including plaster of pre cast pile. All complete as per design, drawing and accepted by the Engineer.	nos	4		
14	Supply, fittings & fixing of 36 " dia. RCC Ring, 2.25" thickness and 6 mm ms bar used as reinforcement three layer horizontally and 6 inch spacing vertically binding with GI wire .1.10'x1.10'inspection pit as per the drawing and instruction of EIC.	nos	13		
15	Supplying fitting fixing of ceramic pan, size of pan 550mmx440x190 mm. RAK, Geat wall or equivalent.	nos	1		
16	Supply, fittings & fixing of pre-cast ring cover 38" , thikness-3" made of 1:2:4 mixing ratio, 8mm dia ms rod (60G) 5" C/C both way as per the drawing and instruction of EIC.	nos	3		
17	Hand Rail: Hand rail made with 1.5" SS pipe, supplying ,casting and installation as per the drawing and instruction of EIC.	nos	1		
18	Soak Pit: Supplying and filling the brick chips in Soak pit as per the drawing and instruction of EIC.	cft	15.00		
19	Other Supplies & Accessories fitting, fixing & supplying				
a	Stud Nail (2.5 inch)	kg	2.00		
b	MS Clamp Size 1-6'' x 2.5''x3mm Thickness	nos	4		
c	Nail Different size (1.5 to 4 inch)	kg	1.50		
d	Hinges	nos	3		
e	Screw for Hinges	dozen	1		
f	Lock Chain (Small for door lock inside & outside with handel)	nos	2		

Bill Of Quantities (BOQ)
For the Twin pit latrine construction
German Red Cross, PMO, Cox's Bazar

Contents of Twin pit Latrine Construction (Twin Pit- Single Cubicle)



Lot 02 & 03: 57 Unit Latrine

Item	Description of work/ Specifications	Unit	Quantity	Unit Price	Amount
g	PVC pipe (3" dia) Gas Pipe	m	6.00		
h	uPVC Long Trap (4" dia)	nos	1		
i	uPVC pipe (4" dia)	m	6.00		
j	Wall Hanger	nos	2		
k	Soap Case (MS)	nos	1		
l	Chain with 50 mm china lock for latrine door	nos	2		
m	Latrine Name Plate Supply: Supplying, fitting and fixing of name plate (1'- 0"x 0'-10"x 17±1 mm thickness) with 2- logo and written text (English), 4 color, all complete as per given sample and instruction of Engineer In Charge.	nos	1		
20	Transportation / carrying / mobilization cost: at Six different villages in baharchora and Teknaf Sadar Union, Teknaf.	nos	1		
Total price for per Unit of latrine (BDT)=					
Total price offer for 57 units of latrine (BDT)=					
Vat (7.5%)					
Total price offer for 57 units of latrine (Including VAT)					

The price must need to including TAX since GRC will deduct TDS (Tax Deduction on Source) & VAT as per government

Validity of this quotation is until 31 December 2022.

Delivery time: (6 Villages in Baharchora and Teknaf Sadar Union, Teknaf.) :

Date of Quotation:

Stamp and Signature of Bidder

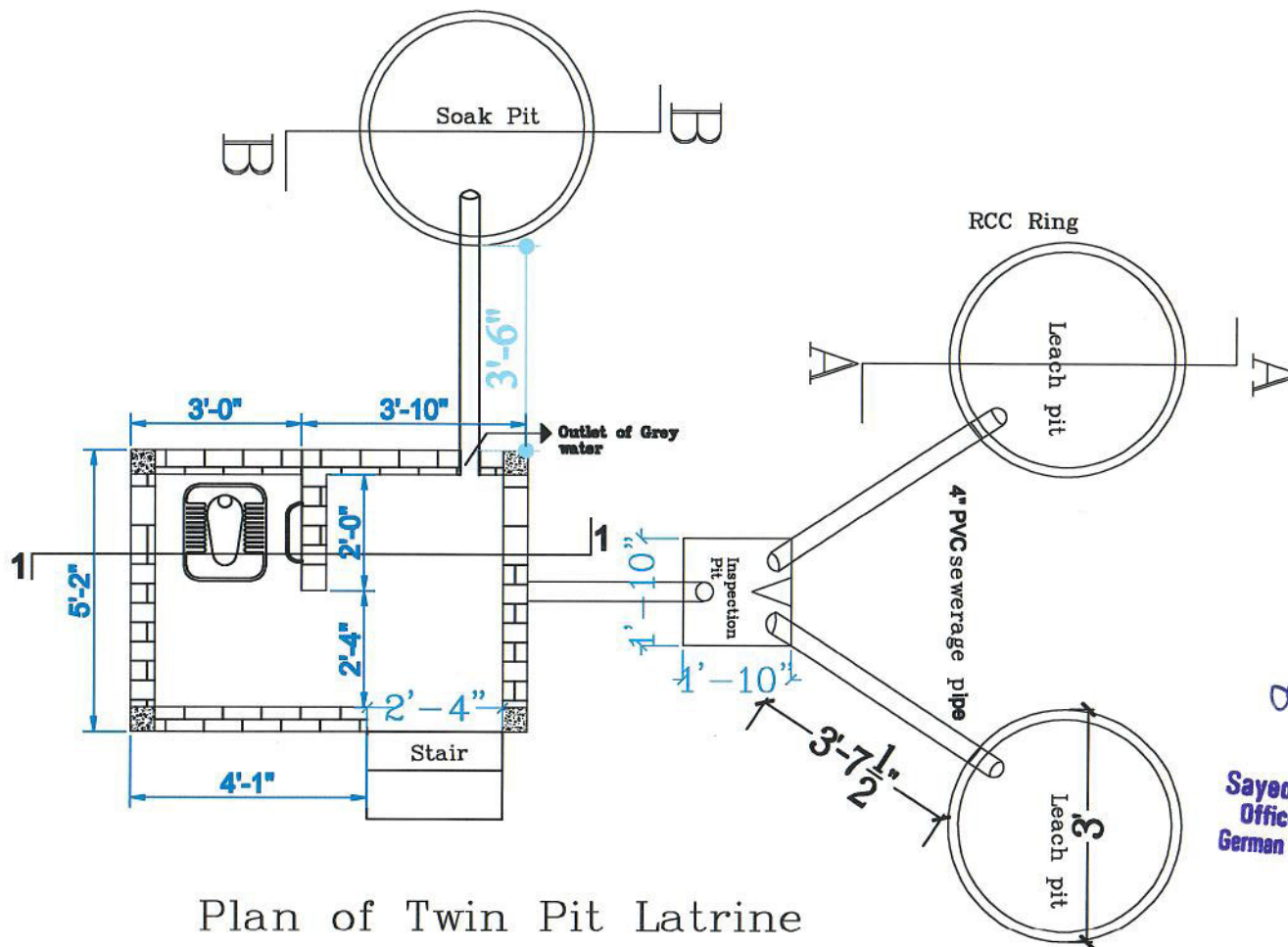

Sayed Ullah Md. Sayem
Sayed Ullah Md. Sayem
 Officer - WASH/ Shelter
 German Red Cross, Bangladesh

Plan of Twin Pit Latrine

RCC ring (1:1.5:3) 3' outer dia, 1' height, thickness 2.25", supplying, fabrication and fixing 6mm dia ms rod @150mm c/c in both direction (vertical & horizontal) with first class brick and 1.6 FM sand.

Project:	Name of work and location:	Description of Drawing:	Design and Drawn by:	Checked and Approved by:
MoFA (Host)	Construction of Twin pit Latrine in Baharchora and Teknaf Sadar Union	Plan of Twin pit Latrine	Sayed Ullah Md. Sayem Officer- Wash/Shelter German Red Cross	Simone Nescetti WASH Delegate German Red Cross-CXB

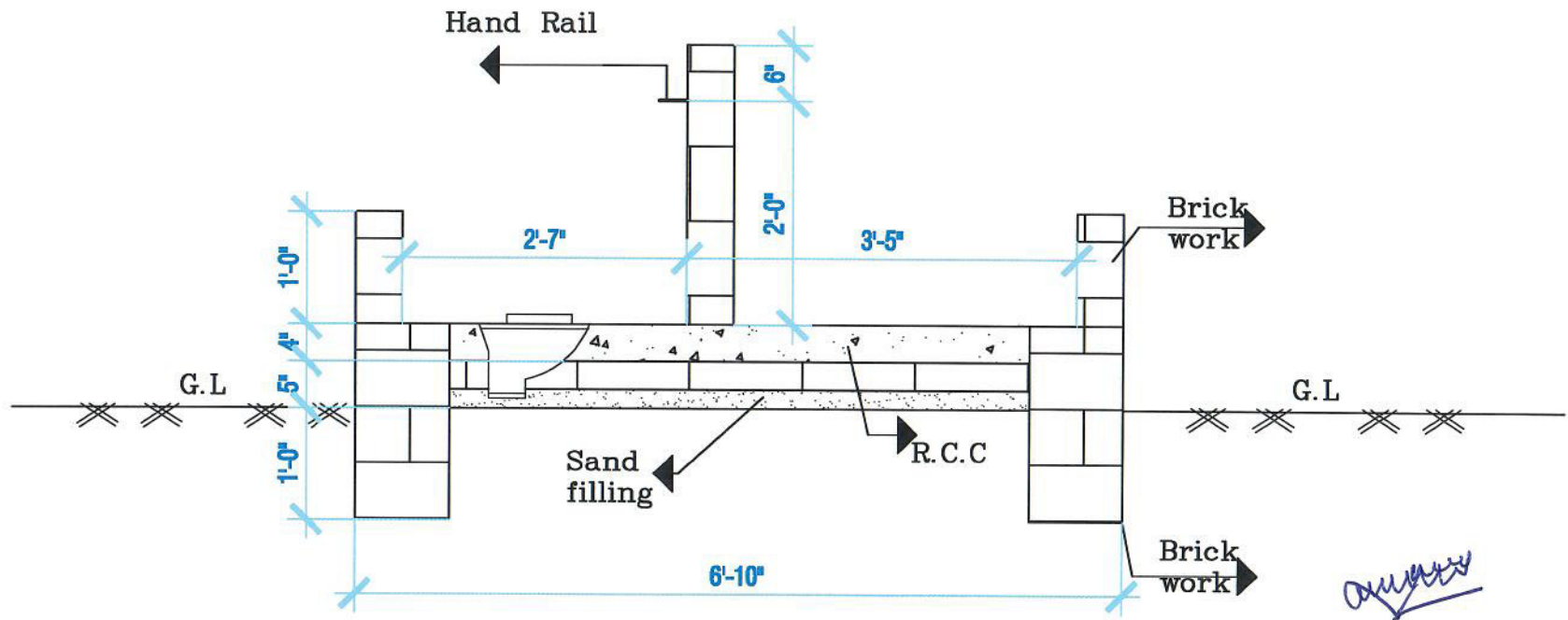

Sayed Ullah Md. Sayem
Sayed Ullah Md. Sayem
 Officer - WASH/ Shelter
 German Red Cross, Bangladesh

Section(1-1) of Twin Pit Latrine

Project:	Name of work and location:	Description of Drawing:	Design and Drawn by:	Checked and Approved by:
MoFA (Host)	Construction of Twin pit Latrine in Baharchora and Teknaf Sadar Union	Section (1-1) of Twin Pit Latrine	Sayed Ullah Md. Sayem Officer- Wash/Shelter German Red Cross	Simone Nescetti WASH Delegate German Red Cross-CXB

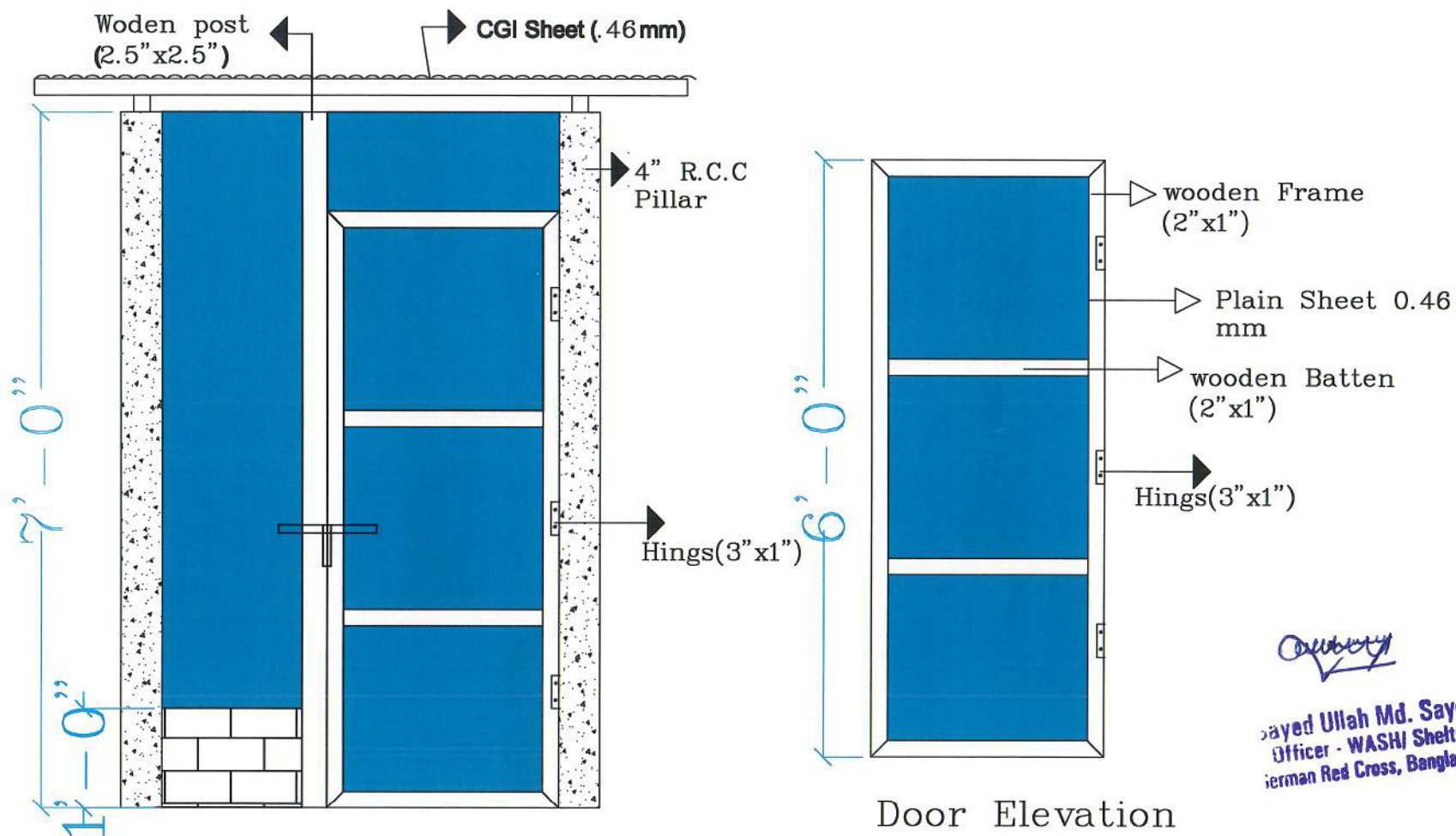

Sayed Ullah Md. Sayem
 Sayed Ullah Md. Sayem
 Officer - WASH/ Shelter
 German Red Cross, Bangladesh

Front Elevation of latrine

Project:	Name of work and location:	Description of Drawing:	Design and Drawn by:	Checked and Approved by:
MoFA (Host)	Construction of Twin pit Latrine in Baharchora and Teknaf Sadar Union	Front Elevation of Latrine	Sayed Ullah Md. Sayem Officer- Wash/Shelter German Red Cross	Simone Nescetti WASH Delegate German Red Cross-CXB

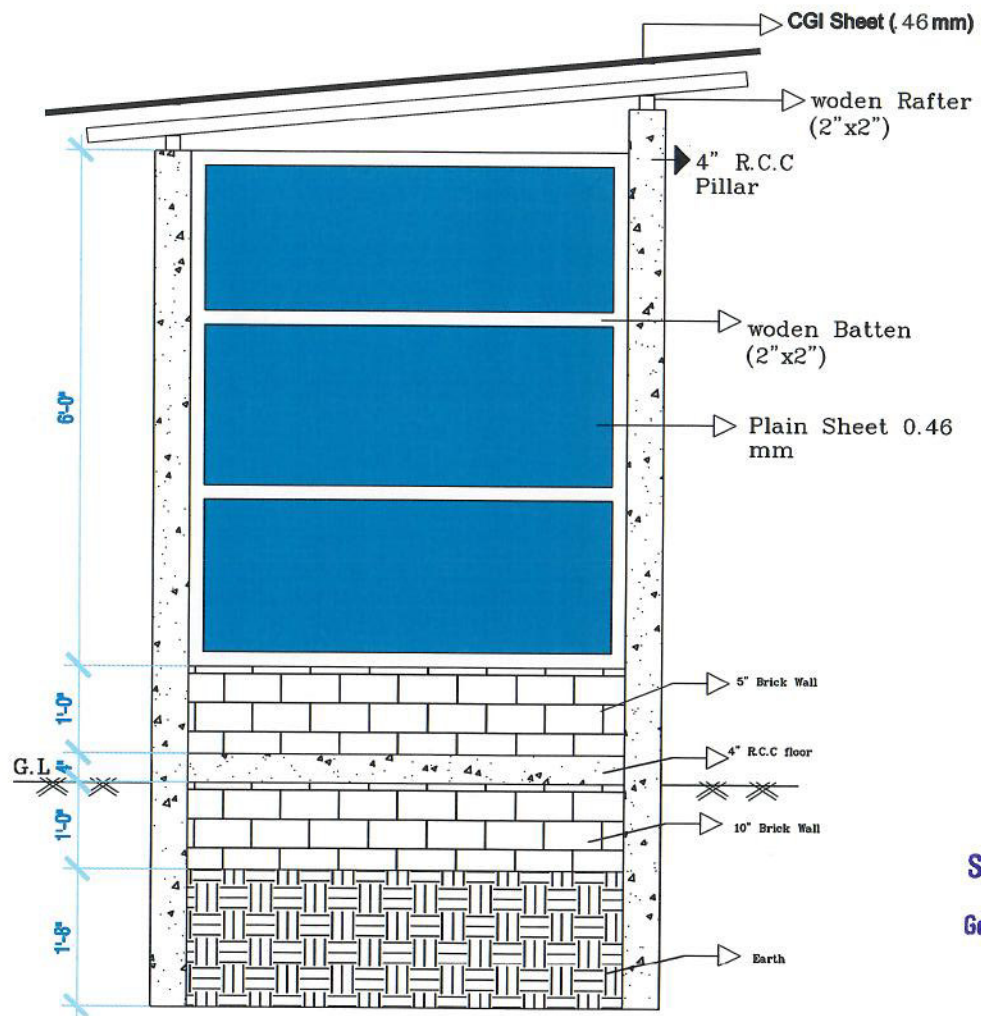



Sayed Ullah Md. Sayem

Sayed Ullah Md. Sayem
 Officer - WASH/ Shelter
 German Red Cross, Bangladesh

Side Elevation of Latrine

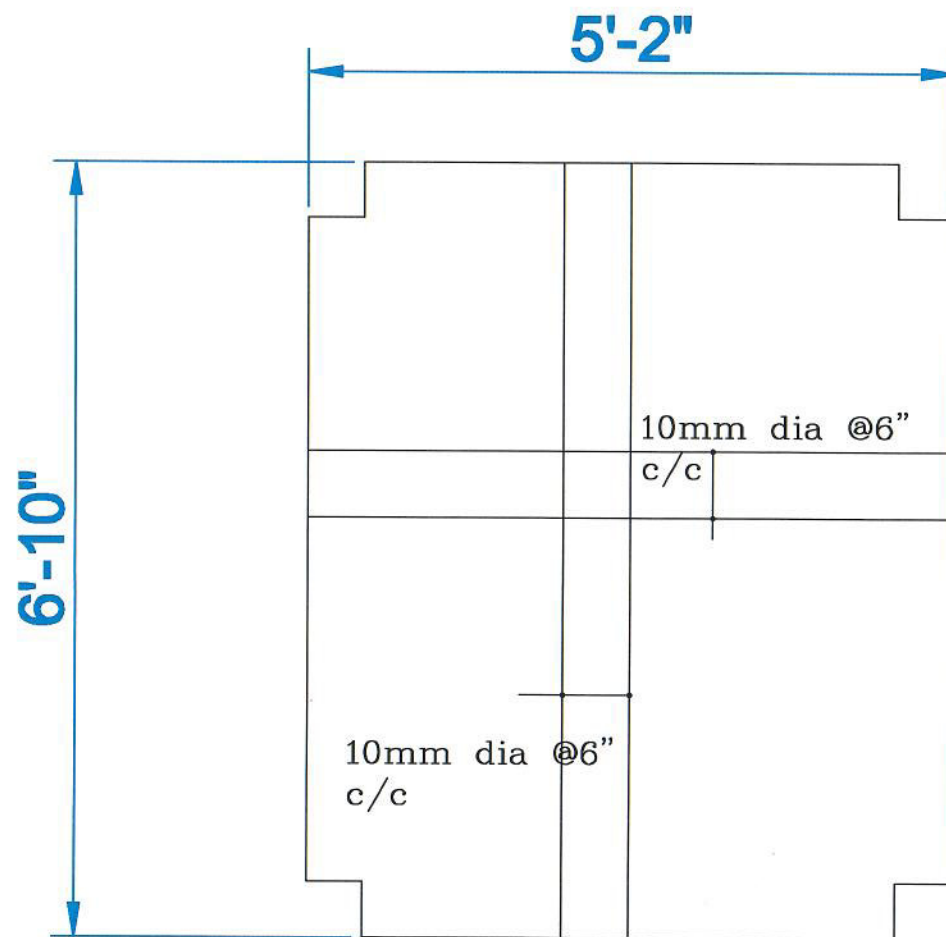
Project:	Name of work and location:	Description of Drawing:	Design and Drawn by:	Checked and Approved by:
MoFA (Host)	Construction of Twin pit Latrine in Baharchora and Teknaf Sadar Union	Side Elevation of Latrine	Sayed Ullah Md. Sayem Officer- Wash/Shelter German Red Cross	Simone Nescetti WASH Delegate German Red Cross-CXB



Sayed Ullah Md. Sayem
 Officer - WASH/ Shelter
 German Red Cross, Bangladesh

Slab Reinforcement

Project:	Name of work and location:	Description of Drawing:	Design and Drawn by:	Checked and Approved by:
MoFA (Host)	Construction of Twin pit Latrine in Baharchora and Teknaf Sadar Union	Slab Reinforcement detail	Sayed Ullah Md. Sayem Officer- Wash/Shelter German Red Cross	Simone Nescetti WASH Delegate German Red Cross-CXB

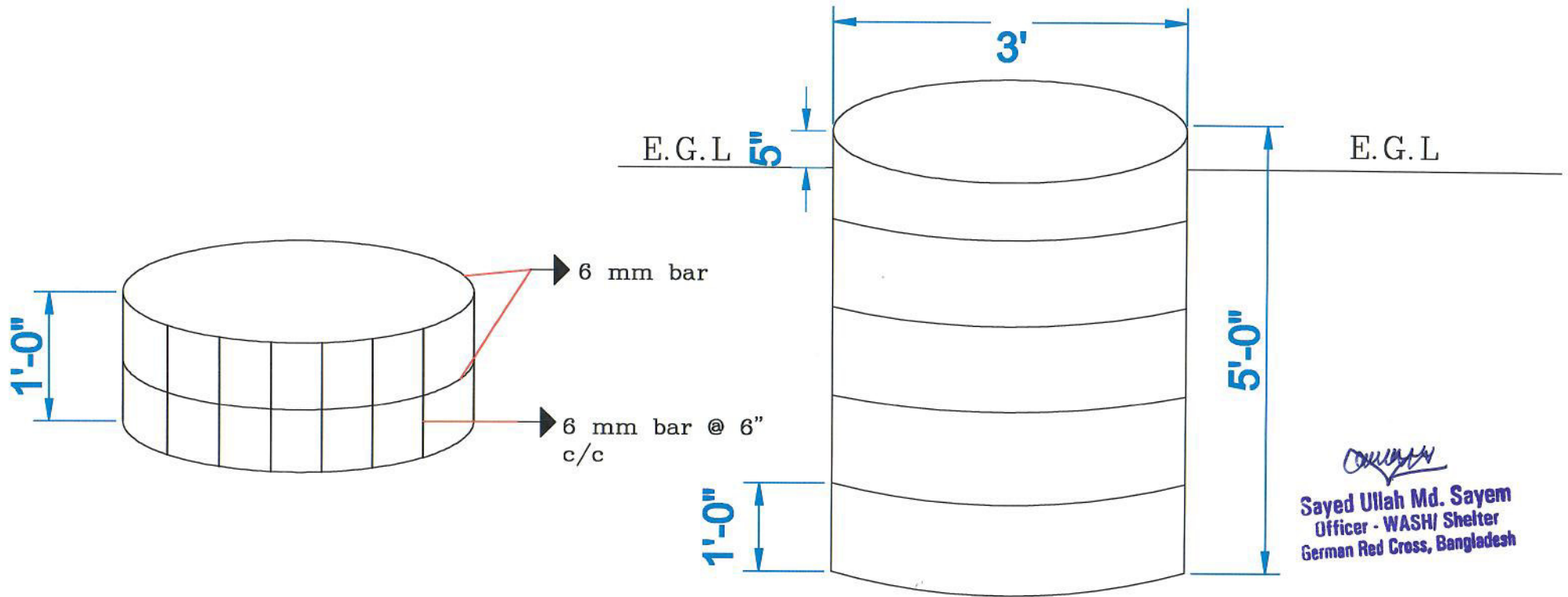

Section(A-A) Detail of Concrete Ring

Project: MoFA (Host)	Name of work and location:	Description of Drawing:	Design and Drawn by:	Checked and Approved by:
	Construction of Twin pit Latrine in Baharchora and Teknaf Sadar Union	Section (A-A) Detail of Concrete Ring	Sayed Ullah Md. Sayem Officer- Wash/Shelter German Red Cross	Simone Nescetti WASH Delegate German Red Cross-CXB

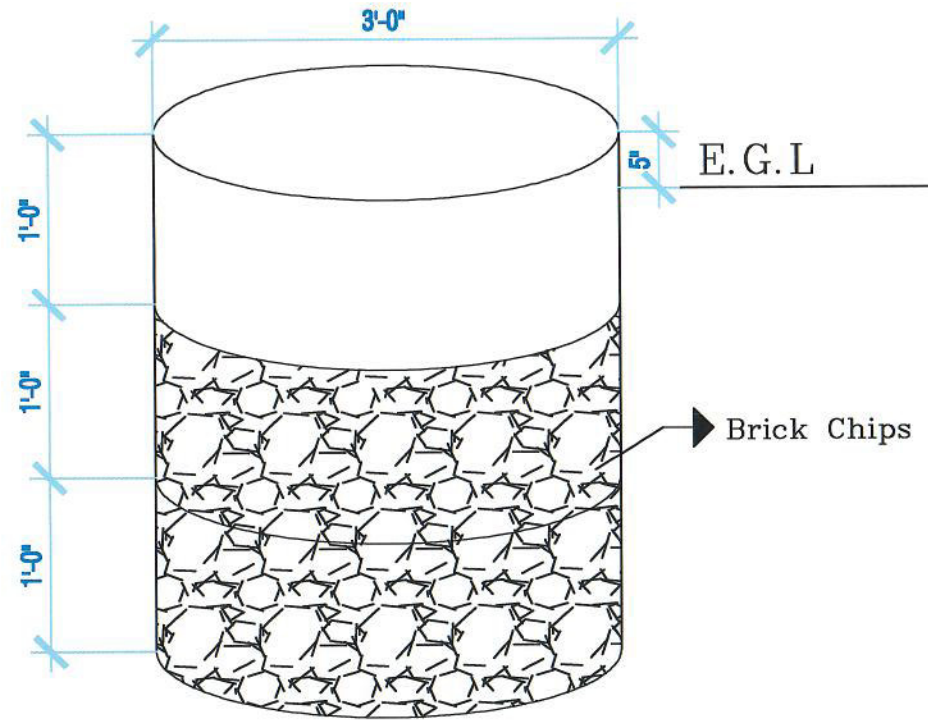

Sayed Ullah Md. Sayem
Sayed Ullah Md. Sayem
 Officer - WASH/ Shelter
 German Red Cross, Bangladesh

Section(B-B) Detail of Soak Pit

Project:	Name of work and location:	Description of Drawing:	Design and Drawn by:	Checked and Approved by:
MoFA (Host)	Construction of Twin pit Latrine in Baharchora and Teknaf Sadar Union	Section (B-B) Detail of Soak pit	Sayed Ullah Md. Sayem Officer- Wash/Shelter German Red Cross	Simone Nescetti WASH Delegate German Red Cross-CXB

Villagewise number of Household Beneficiaries

SL. No.	Village	Ward No.	Union	No. Of Beneficiary	Remarks
1	Holbunia	5	Baharchora	23	
2	Borodail	8	Baharchora	98	
3	Dailpara	6	Teknaf Sadar	1	
4	Moheshkhaliapar	5	Teknaf Sadar	4	
5	Gudarbil	6	Teknaf Sadar	35	
6	Tulatoli	3	Teknaf Sadar	11	
		Total		172	



Sayed Ullah Md. Sayem
Officer - WASH/ Shelter
German Red Cross, Bangladesh



Proposed work plan for the construction of 58-unit twin pit latrines

Activity	Time Frame										Comment	
1	Joint meeting & briefing											Contractor & BDRCS/GRC
2	Material quality check											Milestone. With BDRCS/GRC Engineer in Charge
3	Joint field visit											Contractor & BDRCS/GRC
4	Manufacturing of RCC rings & columns											With BDRCS/GRC Engineer in Charge
5	Mobilization											
6	Digging and foundation brick works (no casting)											Milestone: do not continue without Order to Proceed
7	Casting											
8	Superstructure											
9	Completion											
10	Joint visit / completion certificate											Contractor & BDRCS

Please indicate your work plan by filling the above template with X. You may add activities as needed in the below comments section:



ah Md. Sayem
WASH/ Shelter
Cross, Bangladesh



Proposed work plan for the construction of 57-unit twin pit latrines

Activity	Time Frame										Comment	
1	Joint meeting & briefing											Contractor & BDRCS/GRC
2	Material quality check											Milestone. With BDRCS/GRC Engineer in Charge
3	Joint field visit											Contractor & BDRCS/GRC
4	Manufacturing of RCC rings & columns											With BDRCS/GRC Engineer in Charge
5	Mobilization											
6	Digging and foundation brick works (no casting)											Milestone: do not continue without Order to Proceed
7	Casting											
8	Superstructure											
9	Completion											
10	Joint visit / completion certificate											Contractor & BDRCS

Please indicate your work plan by filling the above template with X. You may add activities as needed in the below comments section:

Handwritten signature
Illah Md. Sayem
 - WASH/ Shelter
 led Cross, Bangladesh

Ref.: CXB-20220911- 01 REQ - Instructions for submissions of quote

The German Red Cross (GRC) is inviting quotations for the provision of **“Construction of Twin pit latrine”** at Six different villages in baharchora and Teknaf Sadar Union, Teknaf. The tenderers are requested to read carefully and ensure compliance with all instructions herein. Non-compliance with instructions in this document may disqualify the bidders from the tender exercise.

1. Procurement Procedure

- a) The procurement is handled via an **Open Procedure.**

2. Deadline of submission and period of validity:

- 1) Deadline of submission is **28.09.2022, 03:00PM. Bangladesh time**
- 2) Your quotation must state the period of validity **until 31st December 2022 from the deadline for the submission.**

3. Costs and ownership of tenders

- 1) Costs incurred by the tenderers in preparing and submitting the quote requests are not reimbursable.
- 2) The GRC retains ownership of all quotes received under this request for quotation. Consequently, tenderers have no right to have their tenders returned to them.

4. Confidentiality and publication

- 1) All recipients of tender documents, whether they submit a tender or not, shall treat the details of the documents as confidential as possible.
- 2) According to German/European procurement law information about the award of contract (name of company, type of product, extent and duration of contract) might be made open to the public unless you disagree within your quotation, giving the reason of refusal.

5. Content of tenders and alternative offers

- 1) All tenders submitted must comply with the requirements in the tender dossier and comprise **(if you are unable to submit any of the following documents will automatically lead to disqualification of the bid):**
 - The quotation about quoted items, including specifications as indicated in the BoQ. The quotation has to be dated, stamped and signed.
 - **VAT registration certificats of compay (if you have).**
 - Company's Registration (Trade License) including TIN certificate
 - Documentation required as indicated in the technical specifications/ design.
 - Documents for Bank solvency
 - Financial offer and payment conditions.
 - **Proposed work plan for the construction of 172 units twin pit latrines**
 - Human Resources engagement plan shall clarify the engagement of workers from the community, including:
 1. number of construction teams
 2. number of skilled workers per construction team (foremen)
 4. availability of site supervisor who will be the main focal point for all field construction activities
 - The tenderers self-declaration **“Certification - Declaration of Conformity”** to be filled out, stamped, signed and submitted together with your quote.
 - Annex **“Federation General Terms & Conditions on Purchasing”** to be stamped, signed and submitted together with your quote.
 - Proof of similar positive experience with RCRC movement/UN/humanitarian organizations
 - Proof of similar work experience especially in Teknaf.

- 2) **Alternative offers are not permitted.** Alternative offers by group of companies with different names will be disqualified on the basis of breaching confidentiality and only the main company offers will be accepted (if specified).
- 3) **Only the original BoQ and work plan templates shall be used for quotation in its original form as provided by GRC in the tender document. Any modification of the provided templates will automatically lead to disqualification of the bid.**

6. Financial offer

- 1) Tenderer must quote by items and by total quantity.
- 2) In case of a calculation mistake, the quoted unit price will be the deterrent.
- 3) Any additional foreseen transport /carrying/mobilization charges have to be offered as separate position and clearly mentioned in the offer as “Additional Cost”.
- 4) Quoted price should be **inclusive of VAT & Tax**.
- 5) All prices are in Taka (BDT)

7. Submission of quote and further communication

- 1) All quotes, including annexes and supporting documents must be submitted in a sealed envelope. Please state on the envelope:

Tender Documents – Please do not open!

Ref. CXB- CXB-20220911-01, Construction of Twin Pit Latrine

Address: German Red Cross - Office Cox’s Bazar,
PMO Office: Room No-119, Motel Labonee, Bangladesh Parjatan
Corporation, Motel Road, Cox’s Bazar. Cox’s Bazar-4700, Bangladesh

- 2) Tenderers could raise any questions regarding the submission of the quotation, materials and construction types for the better understanding. The question should be in written at list 3 days before the deadline for submission of quote, Please note that for any circumstance’s quotation deadline will not extension.
- 3) GRC reserves the right to continue the further communication after submission of quotes via a combination of media (e.g. post, e-mail, phone).
- 4) With submission of your quotation you confirm above mentioned conditions.

8. Evaluation & Award of Contract

- 1) Procedure:
The total quantity of works **(construction of 172 twin pit latrines) will be awarded in three lots (construction of twin pit latrines lot 01-58 units, lot 02-57 units and lot 03-57 units).** The decision for the award of contract will be determined via standard value method. Credit points will be added up through the following criteria:
 - **Financial Offer (50%)**
 - **Technical Offer (50%)**
 - **Delivery time**
 - **Proof of positive similar positive experience with humanitarian actors**
 - **Proof of similar work experience (latrine construction) specially in Teknaf area,**
- 2) In case of competitive procedure GRC reserves the right to award a contract based on the first non-negotiated offer. GRC will not enter into any negotiation.
- 3) The GRC may – but is not obliged to – ask each tenderer individually for clarification of its quote including, samples, breakdowns of prices etc. within a reasonable time limit to be fixed by the evaluation committee. The samples will remain property of the GRC. The tenderer has to bear possible additional costs for a sample delivery abroad.

- 4) Terms of contract
The award will lead to a Purchase Order by GRC and forms a one-time-service. Please find a template attached for your information only.

9) Terms of delivery and payment

- 1) The details and requirements listed in the specifications/ design must be followed at all times.
- 2) A site supervisor, present at the working place during the construction works, is mandatory throughout the duration of the contract as the focal point for all field construction related issues.
- 3) Unless explicitly permitted, GRC does not accept partial shipments.
- 4) The invoice must contain place of delivery and GRC order number.
- 5) Transport charges have to be itemized separately.
- 6) Payments shall be made basis upon completion of works at actual.
- 7) **GRC will deduct TDS (Tax Deduction on Source) and VAT as per governmental rules (if applicable).**
- 8) Payment will be done by AC payee cheque in favor of your company, at actual of satisfactory finished work.
- 9) The construction work is to be delivered in:
*Baharchara union, wards # 5 and 8
(Holbunia and Borodail).
Teknaf Sadar union, wards # 3, 5 and 6
(Dail Para, Moheshkhali Para, Gudarbil & Tulatoli)*
Several delivery locations are to be expected.
- 10) **The bidders should agree on payment after completion of the construction works.**

10) Self-Declaration

The signee of the attached "Declaration of Conformity" (Ref. Annex) assures that

- 1) no reasons for exclusion as mentioned per EU guideline 2014/24/EU, Art. 57, Paragraph 1 exists,
- 2) the tenderer fulfills GRC's claim on good governance, environmental and social responsibility,
- 3) the tenderer agrees on participation in checks and audits as described.

Read and fully understood:

Acknowledgement of the bidder

Certification

- according to procurement procedures for humanitarian actions -

The candidate

name/company

address

represented by

representative's name

address

assures that **none** of the following points apply:

- a) The candidate or company are bankrupt or being wound up, are having their affairs administered by the courts, have entered into an arrangement with creditors, have suspended business activities, are the subject of proceedings concerning those matters, or are in any analogous situation arising from a similar procedure provided for in national legislation or regulations.
- b) The candidate has been convicted of an offence related to his professional conduct by a judgement which has the force of *res judicata*.
- c) The candidate has been guilty of grave professional misconduct proven by any means which the contracting authority can justify.
- d) The candidate has failed to fulfil obligations relating to the payment of social security contributions or the payment of taxes in accordance with the legal provisions of the country in which he is established, with those of the country of the contracting organisation or those of the country where the contract is to be carried out.
- e) The candidate has been the subject of a judgement that has the force of *res judicata* for fraud, corruption, involvement in a criminal organisation or any other illegal activity detrimental to the German Red Cross or European Union's financial interests.
- f) The candidate has been declared to be in serious breach of contract for failure to comply with his contractual obligations pursuant to another procurement procedure or grant award procedure financed by the German Red Cross or European Union's budget.

The Contractor shall respect environmental legislation applicable in the country where the services have to be rendered and internationally agreed core labour standards, e.g. the ILO core labour standards, conventions on freedom of association and collective bargaining, elimination of forced and compulsory labour, elimination of discrimination in respect of employment and occupation, and the abolition of child labour.

The candidate also guarantees access to the relevant financial and accounting files and documents as well as other project related information and company registration data for the purpose of financial checks and audits or due diligence testing conducted by

- the European Commission,
- the European Anti-Fraud Office (OLAF),
- the European Court of Auditors and
- by chartered accountants and auditors commissioned by the German Red Cross or the relevant donor.

Furthermore he confirms to work together with above mentioned parties when contacted directly. The refusal to share requested data and documents may lead to disqualification from tender processes and cancellation of closed contracts.

place, date

signature

FEDERATION GENERAL TERMS & CONDITIONS ON PURCHASING

1. **Acknowledgment:** A duplicate of the Purchase Order or contract is attached and marked "Copy for acknowledgment and acceptance of conditions of contract". Please detach, sign and date this copy and return by registered mail to the Procurement Service, International Federation of Red Cross and Red Crescent Societies, Box 372, 1211 Geneva 19, Switzerland.
2. **Acceptance:** No Purchase Order shall become effective and no contract shall exist until the Federation has received from the Supplier their written acceptance of the conditions which govern the Purchase Order or Contract. This can be accomplished by return of the signed Acknowledgment Copy.
3. **Tax Exemption:** The Supplier's price shall reflect any tax exemption to which the Federation is entitled by reason of any privileges or immunities enjoyed by it. If it is subsequently determined that any taxes which have been included in the price are not required to be paid, the Federation shall deduct the amount from the contract price, and any amounts already paid shall be refunded.
4. **Discount:** Time in connection with any discounts offered will be computed from the date of receipt by the Federation of full documentation as specified by the Purchase Order, Contract or Annex thereto.
5. **Warranty:** The Supplier warrants the goods or services furnished under this Purchase Order / Contract to be fit for their intended use and free from defects in workmanship and materials, and indemnifies the Federation against any claims resulting therefrom. This warranty is without prejudice to any further guarantees that the Supplier provides to its purchasers - such guarantees shall apply to the goods or services that are the subject of this Purchase Order / Contract.
6. **Inspection:** The duly authorized representatives of the Federation shall have the right to inspect the goods or services that are the subject of this Purchase Order / Contract at the Supplier's stores, during manufacture, in the ports or at places of shipment, and the Supplier shall cooperate and provide all facilities for such inspection. The Federation may issue a written waiver of inspection at its discretion. Any inspection carried out by representatives of the Federation or any waiver thereof shall not prejudice the implementation of any other relevant provisions of this Purchase Order / Contract concerning obligations of the Supplier, such as warranty or conformance of goods or services to specifications.
7. **Packing:** The Supplier shall pack all goods with new sound materials and with every care in accordance with normal commercial standards of export packing for the type of goods specified herein. Packing materials must be adequate to safeguard the goods while in transit. The Supplier shall be responsible for any damage or loss which can be shown to have resulted from faulty or inadequate packing.
8. **Export License:** The Purchase Order / Contract is subject to the obtaining of any export license or other governmental authorization which may be required. It shall be the responsibility of the Supplier to inform the Federation beforehand of such restrictions and obtain such license or authorization, but the Federation will use its best endeavors to assist. In the event of refusal thereof, the Purchase Order / Contract will be annulled and all claims between the parties automatically waived.
9. **Force Majeure:** Force majeure, as used herein, shall mean acts of God, laws or regulations, industrial disturbances, acts of the public enemy, civil disturbances, explosions and any other similar cause of equivalent force not caused by, nor within the control of either party, and which neither party is able to overcome. As soon as possible after the occurrence of any force majeure event and within not more than 15 days, either party thereby rendered unable, wholly or in part, to perform its obligations under the Purchase Order / Contract, shall give notice and full particulars in writing to the other party. The party receiving such notice shall then have the right to terminate the Purchase Order / Contract by giving seven days written notice of termination. On termination of the Purchase Order / Contract, the Supplier shall return any deposit or advance payment by the Federation.
10. **Default:** In case of default by the Supplier, including but not limited to failure or refusal to make deliveries within the time limit specified, the Federation terminate the Purchase Order / Contract by written notice with immediate effect and may procure the goods or services from other sources and hold the Supplier responsible for any excess costs occasioned thereby. The Supplier shall have no right to receive payment for deliveries dispatched following receipt of such notice.
11. **Conformity with Specifications:** In the case of goods or services purchased on the basis of specifications, the Supplier warrants their conformity. The Federation shall have the right to reject and refuse payment for all non-conforming goods or services. In case of non-conformity the Supplier may propose a suitable alternative for the Federation's consideration.
12. **Ethical Conditions:** The Supplier shall not be on bankruptcy, wound up or have affairs administered by the Court, neither have entered into an arrangement with credits, nor have suspended business activities, or be subject to proceedings concerning those matters or be in any analogous situation arising from a similar procedure provided for in national legislation or regulations.
The Supplier shall neither be guilty of grave professional misconduct nor be convicted of the same.
The Supplier shall not be subject to a judgment that has force of Res Judicata for fraud, corruption, involvement in a criminal organization or any other illegal activity.
The Supplier shall have fulfilled obligations relating to the payment of social security contributions and taxes in accordance with the legal provisions of the country in which he is established or the country where the contract is performed.
The Supplier guarantees that he is respecting fundamental rights and is in no way complicit in human rights abuses. He is not exploiting child labour and forced labour and respects the basic social rights and working conditions in the countries involved.
13. **Disputes-Arbitration:** Any dispute, claim, or controversy arising out of or in relation to this Purchase Order / Contract, or the validity, breach, or termination thereof, shall be referred to arbitration under the United Nations Commission on International Trade Law Arbitration Rules, subject to such modification as the parties may agree in writing. The arbitration shall be conducted in the English language and shall be governed by the substantive law of Switzerland. The arbitral tribunal shall have no authority to award punitive damages. The parties agree to be bound by any arbitration award rendered in accordance with this paragraph as final adjudication of any such dispute, claim or controversy.
14. **Privileges and Immunities:** Nothing in or relating to this Purchase Order / Contract shall constitute or be deemed a waiver, express or implied, of any privilege or immunity enjoyed by the Federation, whether pursuant to existing conventions, treaties, or agreements, such as the agreement of 29 November 1996 between the Federation and the Swiss Federal Council regarding the legal status of the Federation in Switzerland, or any other convention, treaty, or agreement which may come into force.
15. **Assignment:** The Supplier shall not assign, transfer, pledge or make other disposition of this Purchase Order / Contract or of any of the Supplier's rights, claims or obligations hereunder except with the prior written consent of the Federation.
16. **Bankruptcy:** Should the Supplier file any petition for bankruptcy or make a general assignment for the benefit of its creditors, or should a receiver be appointed on account of the Supplier's insolvency, the Federation may terminate this Purchase Order / Contract by written notice with immediate effect.
17. **Advertising:** Unless authorized in advance in writing by the Federation, the Supplier shall not advertise or otherwise make public the fact that it is a Supplier to the Federation and / or any National Red Cross or Red Crescent Society, or use the name, emblem or official seal of any of them or any abbreviation or derivation thereof whether for advertising or any other purposes.
18. **Officials Not to Benefit:** The Supplier represents and warrants that no official of the International Federation of Red Cross and Red Crescent Societies has been, or shall be, admitted by the Supplier to any direct or indirect benefit arising from this Purchase Order / Contract or the award thereof. The Supplier agrees that breach of this provision is a breach of an essential term of this Purchase Order / Contract.
19. **Amendments:** No changes or modifications to this Purchase Order / Contract shall be valid unless set forth in writing signed by both parties.
20. **Notice:** Service of any notice shall be deemed to be good if sent by registered mail, telex, fax or cable to the addresses of both parties, set out in the heading of this Purchase Order / Contract.
21. **Governing Law:** This Purchase Order / Contract is considered to be concluded in Geneva, Switzerland and shall be governed by Swiss law.



Ref. No.: CXB-XXXXXXXXXX RFQ Twin-pit Latrine Construction

Date: XXXXXXXX

To,
XXXXXXXXXX
XXXXXXXXXX

Attn.: Mr. XXXXXXXXXXXX

Subject: Work Order for the construction of Twin-pit Latrines at Teknaf, Cox's Bazar

Dear Sir,

Kindly refer to your submitted quotation dated xxxxxxxxxx regarding the construction of xxxx Twin-pit Latrines at German Red Cross, Cox's Bazar. The International Federation of Red Cross and Red Crescent Societies (IFRC) German Red Cross (GRC), Bangladesh Country Office is pleased to place an order according of our instructions for submissions of quote. Details given as below:

1. Name of the Items, Specifications, Quantity, Unit Price & Total Price:

SL	Items	Specification with units	Quantity	Unit	Total (BDT)
01	Twin-pit Latrines	As per attached BoQ	xxxxxxx	xxxx	xxxxxx
<i>In Word: Two Million Nine Hundred Eighty Thousand and Eight Hundred only.</i>					

Price is inclusive of all costs such as mobilizing, materials, loading, delivery, unloading, wages, taxes, etc.

2. Delivery Locations and Delivery Schedule:

Goods have to be delivered to the location mentioned below:

No.	Delivery Locations	Delivery Period
1	Teknaf, Cox's Bazar.	The construction of xxxxxxx after issuing the work order. (Delivery date and time and address of constructions place will be provided in time).

The supplier shall be responsible for delivery of goods and services as mentioned above.

Any possible delay has to be announced immediately by phone in advance and additionally documented by email.

3. Specifications: The detailed specifications are given in Clause 1 in the tender notice and in the BoQ. Detailed descriptions of the scope of work are listed in the Technical Annex, which is an essential part of the contract. All the specifications and instructions must be adhered to. The goods and services must meet the specifications mentioned in Clause 1 and should be fit for human consumption and intended use.

4. **Delivery period:** The works must be completed according Clause 2.
5. **Documents:** Supplier should provide **(a)** two copies of original commercial invoice, **(b)** three copies of packing list, **(c)** three copies of receipted delivery challan. *One set of documents mentioned under (b) and (c) have to accompany the consignment, one set for the buyer and one set for the consignee at least 1 day before the delivery of goods.* Consignee will provide Goods Receipt Note (GRN).
6. **Monitoring/Inspection:** The supplies must meet the required specifications mentioned in Clause 1 and in the tender notice. Visual checking/inspection of quality & quantity will be carried out by IFRC/GRC and BDRCS staff. Supplies not found in accordance with the specifications will not be accepted and has to be replaced by the supplier at their own cost. The supplier will be responsible for any damage or loss before final handing over of the supplies to the consignee. After the supply is completed, a GRN will be issued by the consignee, which will be necessary for release of payment.
7. **Title of Goods:** Legal title and hence responsibility for the supplies will not pass to IFRC/GRC until the supplies are delivered and accepted after satisfactory inspection report from the IFRC and BDRCS team.
8. **Invoice:** Two Copies to be sent to IFRC/GRC quoting this purchase contract number. No claims against our payment will be accepted after one month from the date of the payment.
9. **Income Tax:** While making the payment the Advance Income Tax (AIT) will be deducted from the invoice as per the TDS Regulations of the Government of Bangladesh (Tax deduction on source).
10. **Terms & Conditions:** The terms of RFQ and the IFRC/GRC general Terms and Conditions of Purchase form part of this contract.
11. **Conflict of Interest:** Subsequent to the signing of this contract should any supplier be discovered to have any connection whatsoever to the IFRC/GRC this contract shall immediately become null and void. All costs in relation to cancellation of the contract shall be borne by the supplier and in addition, the supplier shall forfeit his/her earnest money and security money.
12. **Force Majeure:** Should any extraordinary and unforeseen circumstances arise, such as fire, riot, civil commotion, epidemic, plague, flood, accident, shutdown (hartal) and/or war preventing either contracting party from fully or partially carrying out its obligations under the contract, the party so prevented shall inform the other party in immediately per phone call and for longer duration writing of the causes of such failure within three days from the beginning thereof and shall not be liable for performance of the contract wholly or partially to the extent of non-performance, as the case may be. The independent authorities concerned shall authenticate prevalence of such circumstances.
13. **Penalty Clause:** Finishing the works and services after the agreed delivery schedule will be subject to deduction of damages from the invoice @ 0.5% per day up to maximum 5% of the total order value for a maximum period of 10 days. If the supplier failed to deliver the works and services after 10 days of the delayed delivery period, the contract will be void and null, and the Performance Guaranty will be forfeited besides other action for non-performance of the contract.
14. **Disputes:** All differences concerning the interpretation of the present contract shall be solved and settled in a friendly way through mutual understanding. Should the issue not be resolved within 90 days, the IFRC/GRC dispute provision in Article 12 of the Federation's Terms and General Conditions on Purchasing shall apply.

15. Effective Date: This purchase order comes into force on date of signature by both parties of this agreement.

16. Buyers terms: Except where expressly varied in this contract, buyer's terms and conditions apply.

Approved by:

Mr. Gaurav Ray

Senior Representative

German Red Cross, Bangladesh

Agreed and acknowledged to above terms and conditions:

xxxxxxx

xxxxxxx

xxxxxxx

Date: